

# Next-Generation Label Printing Scale

## Smart. Proven. Future-proof



### Easy Operation

User compatible to previous scales, logical menu structure for simplified navigation, faster and more flexible keyboard and proven functionalities, extended with many new and exciting possibilities: bPlus continues the success story of METTLER TOLEDO label printing scales.



### Quality

bPlus lives up to every expectation associated with quality. Stylish design, top-quality components like an incredibly fast printer – plus all the carefully considered details combined to create a tangible difference.



### Smart Management

Keep firmware and configurations data up to date and optimize the operational uptime and system continuity with feature-rich and legally compliant application software. Furthermore, bPlus enables a convenient setup and configuration by scale configuration software or easy USB configuration loading.



### Investment Protection

bPlus convinces with a fast and flexible keyboard, less standby-power and enables quick paper roll changes. It combines simple ergonomic operation and high functionality – thereby setting the new standard in its performance class.



### bPlus-H2

Label printing scale for fast and accurate weighing and service

bPlus is an ergonomic and dependable retail scale designed for grocery stores and supermarkets that place high demands on the quality and reliability of the equipment they work with. Its ingenious details and smart software will help to simplify the scale-, sales and category-management processes and hence save valuable time, day after day. bPlus is perfect for retailers who are looking to invest wisely in future proof weighing technology that will help them focus on what really matters: sales and profit. That's why every part of a METTLER TOLEDO bPlus scale is carefully engineered to provide you with outstanding benefits. Because the difference is in the details.

## Technical Data

### bPlus-H2

#### Operator Display\*

High contrast LCD display  
 Weight: 6 digits  
 Tare: 5 digits  
 Price/kg: 6 digits  
 Total: 7 digits  
 Text line: 16 alphanumeric characters (dot matrix line)

#### Customer Display\*

High contrast LCD display  
 Weight: 6 digits  
 Tare: 5 digits  
 Price/kg: 6 digits  
 Total: 7 digits  
 Text line: 16 alphanumeric characters (dot matrix line)

#### Keyboard

Light touch keyboard; easy to take out for cleaning  
 99 light touch keys with pressure point  
 71 preset keys with two layers for assigning 142 PLUs  
 Separate individually configurable function keys

#### Printer

Thermal printer for receipts, labels  
 Printing speed: up to 125 millimeters/second  
 Print resolution: 203 dpi  
 Roll width: 65 mm (liner label),  
 Printable width: 56 mm  
 Roll diameter: max. 120 mm

#### Data Storage

32 MB internal memory

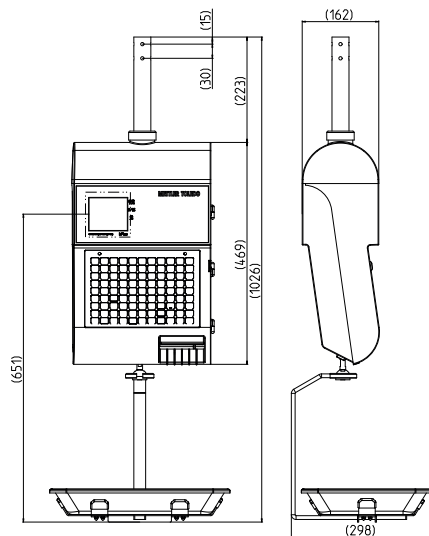

all dimensions in mm

#### Interfaces

2 RS232 serial interfaces  
 1 RJ45 Ethernet interface  
 2 USB interfaces  
 1 RJ11 interface (12 V) for controlling the cash register

#### Networking and Data Transfer

10/100 Base T Ethernet, TCP/IP, USB, DHCP, Wireless LAN\*\*  
 DHCP support for automated network setup  
 Hub less network connection  
 Automatic backup  
 Smart management functions for transmitting and securing production and configuration data via USB stick

#### Housing Color

Grey

#### Weighing Range

6/15 kg

#### Graduation

2/5 g

#### Minimum capacity

40 g

Automatic zero-setting

#### Accessories and Options

Power cord  
 Integrated wireless kit for wireless data transmission according to IEEE802.11b/g/n standard

#### Power Consumption

100–240 V AC, 50/60 Hz  
 Standby power consumption: < 0,5 W  
 Working power efficiency: > 85 percent



\* 1 line dot Matrix display with white backlight

\*\* optional

#### Optimum support in the fresh food category

- Fast weighing, serving and labeling
- Proven, mature software extended with next-generation functionalities
- Compatibility with its predecessor, makes it easy for employees who know predecessor model to work with the new scale
- Smart software solutions allow to run bPlus and predecessor models in one store
- Professional PC-software for integration with ERP system
- Smart management for optimal data integrity and operational uptime of the scales
- Easy advertising on the scale by adding magnetic pictures to the scale housing

Advertising on the customer side of the scale can easily be done by adding a magnetic picture to the scale housing.



[www.mt.com/retail](http://www.mt.com/retail)

For more information



#### METTLER TOLEDO Group

Retail Division  
 Local contact: [www.mt.com/contacts](http://www.mt.com/contacts)

Subject to technical changes  
 © 10/2017 METTLER TOLEDO. All rights reserved  
 Global MarCom 2228 JS/JB