

Smart Touchscreen Weighing Models and Variants

FreshBase U2 with customer display

METTLER TOLEDO FreshBase U2 with upper keyboard and customer display is a high-performance counter scale for service counters – whether in supermarkets, butchers' shops or local deli stores. The 7-inch color customer display with brilliant LED backlight technology guarantees extremely high viewing angle stability, anti-glare properties and excellent brightness and contrast values, thus ensuring optimal legibility and reinforcing customer trust.

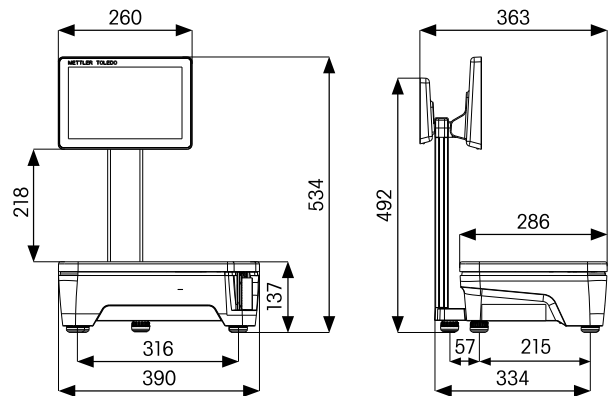

	FreshBase U2 with customer display		
Weighing range	3/6 kg	6/15 kg	15/30 kg
Increments	1/2 g	2/5 g	5/10 g
Minimum capacity	20 g	40 g	100 g

FreshBase U3 without customer display

METTLER TOLEDO FreshBase U3 without customer display is a self-service scale which is easy and intuitive for customers to use based on a convenient and ergonomic touchscreen. The On/Off button is placed out of sight on the underside of the device, which prevents the scale from being inadvertently or willfully switched off. Thanks to the anti-stick coating on the device housing, labels can be removed easily without leaving a residue.

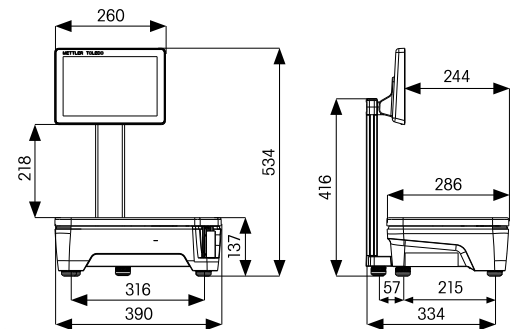

	FreshBase U3 without customer display
Weighing range	6/15 kg
Increments	2/5 g
Minimum capacity	40 g

FreshBase C2 with customer display

METTLER TOLEDO FreshBase C2 is a robust, high-performance compact scale with a 7-inch color customer display which is ideal for use at hot-food counters and service counters where space is limited. Thanks to the flat design, it does not obstruct the line of sight between sales employees and customers, plus it allows employees quick and easy access to products in the display case.

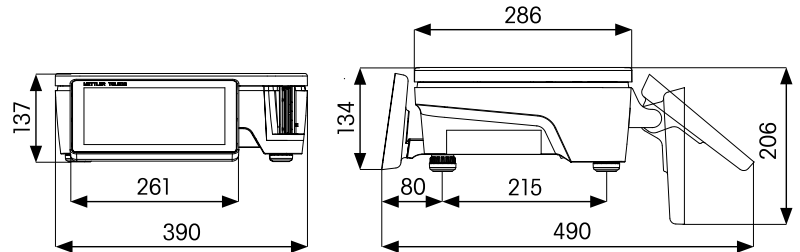

	FreshBase C2 with customer display		
Weighing range	3/6 kg	6/15 kg	15/30 kg
Increments	1/2 g	2/5 g	5/10 g
Minimum capacity	20 g	40 g	100 g

FreshBase T2 with customer display

METTLER TOLEDO FreshBase T2 is a robust, high-performance compact scale with a 7-inch color customer display which is ideal for use at high hot-food counters and service counters where space is limited and good visibility of the customer display for shoppers is required. Thanks to the low keyboard it allows employees quick and ergonomic operation.

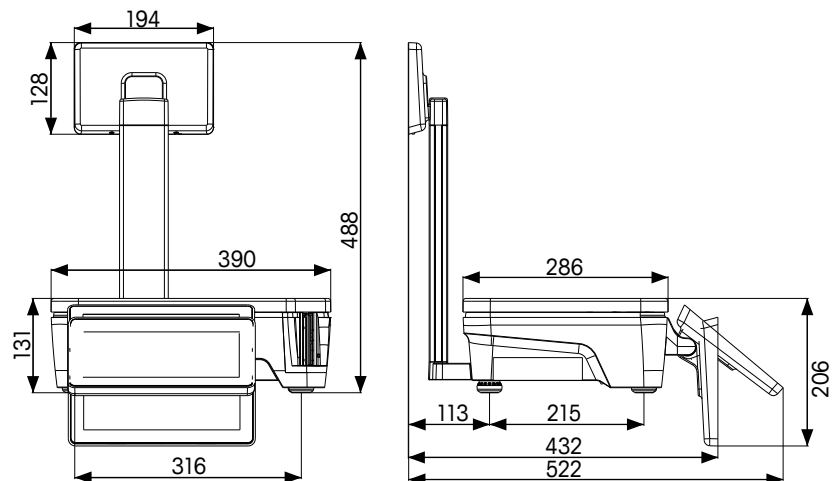

	FreshBase T2 with customer display		
Weighing range	3/6 kg	6/15 kg	15/30 kg
Increments	1/2 g	2/5 g	5/10 g
Minimum capacity	20 g	40 g	100 g

All dimensions in millimeters

Mettler-Toledo (Changzhou)

Measurement Technology Co., Ltd.
No.111, Taihu West Road, Xinbei District.
Changzhou, 21312-5. China

www.mt.com/freshbase

For more information



ISO 9001 quality management certification
ISO 14001 environmental management certification

Subject to technical changes.
© 04/2016 Mettler-Toledo (Changzhou)
Measurement Technology Co., Ltd.
Printed in China 30332106
Global MarCom Switzerland, 1776 MC/MD